



World Data on Education

Données mondiales de l'éducation

Datos Mundiales de Educación

VII Ed. 2010/11

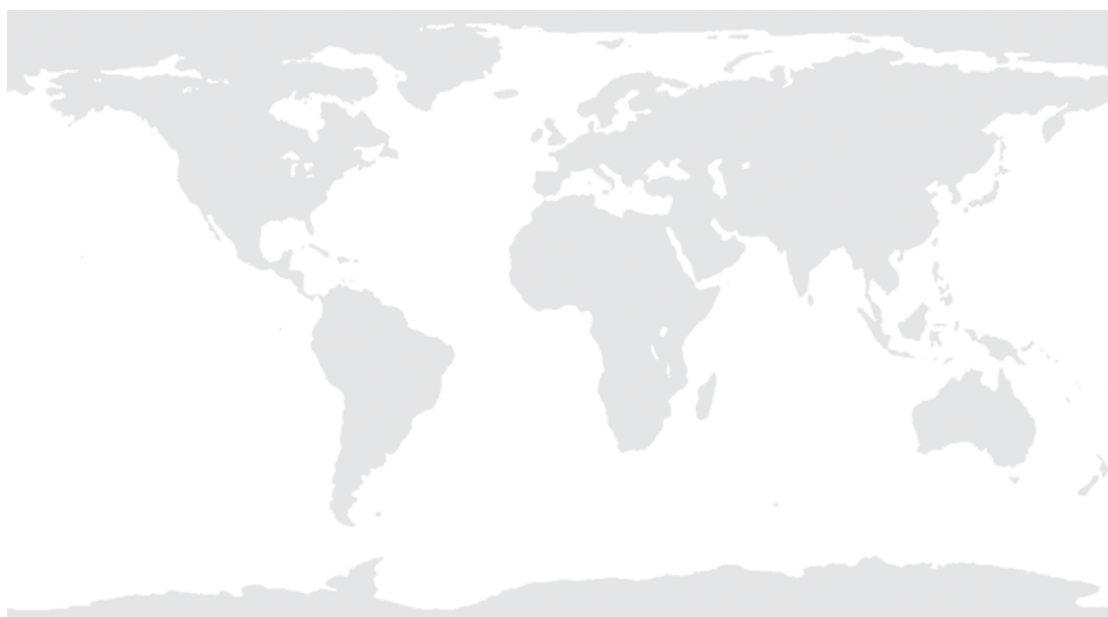

Dominica

Revised version, June 2010.

Principles and general objectives of education

The Government of the Commonwealth of Dominica is convinced that an effective education system is indispensable to development. Specifically, the Government recognizes that an educated human resource base is essential for economic productivity, political stability and social well-being.

A fundamental guiding principle of the education system is the view that all citizens, regardless of gender, class, culture or ethnic origin have the ability to learn and should be accorded the opportunity to develop that potential to the fullest.

It is hoped therefore that in the process of education, ethical and moral values are established and reinforced. At the same time, the system must engender the capacity for all the people to develop leadership skills, stimulate and empower the quest for fundamental values of justice, equality, respect and truth—all prerequisites for building a strong democracy.

Concomitantly, the main goals are to develop the individual's intellectual skills, a capacity for independent thought and critical analysis and the productive capacity for socio-economic development. There is also an underlying principle or objective that seeks to develop appropriate values and behaviour that are consistent with the country's cultural identity and heritage.

According to the 2004 Vision and Mission Statements of the Ministry of Education, the purpose of education in Dominica is to provide all citizens with high quality education and training and facilitate individual well-being and national development. The graduate of the Dominican education system is envisaged as a positive person who is able to communicate effectively with words, numbers, visual images, symbols and sounds, computer competent, skilled in science, technology and their applications, confident, self reliant, capable of sound moral and ethical judgements, someone who respects and values the well-being of himself/ herself, other people, the environment and their inter-dependence: an individual who engages in learning as a lifelong activity and is prepared to make decisions and take responsibility for the results of those decisions at home, at the workplace and in the wider society. (Ministry of Education, 2006).

Laws and other basic regulations concerning education

The **Education Act No. 11** of 1997 was passed in the House of Assembly (Parliament) on 10 October 1997. It is based on the Harmonized OECS Education Bill. This Act and its subsequent amendments provide the regulatory framework for the delivery of educational services at all levels.

The Act states that all persons are entitled to receive an educational programme appropriate to their needs, subject to the availability of resources. Section



27 of the Act provides for compulsory attendance at school between the ages of 5 and 16 years.

There are several new and improved provisions, which cater to those with special education needs, as well as those students who are challenged, physically or mentally. The role, functions and responsibilities of the Chief Education Officer are clearly defined. So, too, are the rights and responsibilities of students, teachers and parents. The **Education (Amendment) Act No. 6** of 2002 repelled the definition of 'pre-primary education' under the Act of 1997, and introduced the notion of 'early childhood education' intended as "education and care suited to the requirements of children under five years of age provided either within a primary school or in an early childhood education facility (a school, day-care centre, crèche or other similar institution) specially designed for that purpose."

Much greater involvement is prescribed in the Act for the management of government-assisted schools. Corporal punishment has been restricted to the principal and deputy, with the Minister given the power to abolish such punishment by Order published in the Official Gazette subject to an affirmative vote in Parliament.

This new legislative enactment also calls for further transparency in the management and utilization of resources. Special provisions have been made for annual audits by the Director of Audit, or an officer authorised by him/her. Also, under the 1997 Act (Section 70), the Minister has been given the power to appoint the Board of Management of assisted private secondary schools.

The **Education (Early Childhood Education) Regulations No. 39** of 11 July 2003 deal with issues related to registration of early childhood education facilities, environmental and other related standards and requirements, as well as admission, educational programmes (curriculum development) and staff

The **Education (Council on Early Childhood Education) Order No. 14** of 21 June 2005 provides for the establishment of the Council and its advisory functions on policies, standards, requirements, and other regulatory issues in the field of early childhood education and development.

On the basis of the **Dominica State College Act No. 4** of 2000, the Dominica State College, a national publicly funded institution, was established in 2002 by merging the four publicly-owned tertiary education facilities existing at that time.

Administration and management of the education system

The Education Act (1997) confers a wide array of powers on the Minister of Education and also imposes a considerable range of duties and responsibilities on him/her for the administration of education in Dominica.

The Law requires the Minister to establish a relevant, varied and comprehensive education system that is characterized by excellence. The Minister also has power for framing educational policy. Essentially, the administration and management of the education system is vested in the Minister and the **Ministry of**



Education and Human Resources Development (previously the Ministry of Education, Sports and Youth Affairs). The **Curriculum Unit**, in charge of developing curricula, teaching materials and tests, was established within the Ministry of Education in 1998. Adult education is under the responsibility of the **Ministry of Social Services, Community Development and Gender Affairs**, while activities in the domain of skills training are coordinated by the **Ministry of Culture, Youth and Sports**.

The Minister of Education has power to appoint an **Education Advisory Board** as well as **School Management Boards**. Under the Act, the Advisory Board shall advise the Minister on educational matters, respecting the performance of any of his/her responsibilities; and on any matter relating to the promotion of education.

All secondary assisted, as well as private schools, have Management Boards. These boards have responsibility for policy formulation, financial management and infrastructural development. Although the new law makes provision for boards at government secondary schools, these have not been commissioned.

More than 50% of primary schools have established Parent-Teacher Associations (PTAs), while all secondary schools operate with functional PTAs. These bodies have been particularly useful in submitting advice to government and providing assistance with policy formulation on matters of discipline, institutional and infrastructural development.

The **Council on Early Childhood Education (ECE)**, established in 2005, provides advice to the Minister of Education on ECE policies, standards and requirements for ECE facilities, and other regulatory issues in the field of early childhood education and development. Although ECE is not within the scope of the Education Act, there are several establishments in the island providing early intervention in core areas for the 3-5-year-olds.

There are three other public institutions that play a significant role in education. These are: the **Establishment, Personnel and Training Department (EPTD)**; the **Public Service Commission (PSC)**; and the **Ministry of Finance**.

The EPTD has responsibility for general management and control of the public service subject to the Constitution and the Public Service Act. These two instruments define powers of ministers and the role of permanent secretaries in public service management. Over the last decade, the EPTD had been implementing reforms aimed at greater efficiency and effectiveness in the delivery of government services.

The Department has also introduced standards of performance and criteria of accountability amongst teachers and principals. Recently, these standards and the Performance Appraisal System have been undergoing critical review for greater objectivity and acceptance.

Appointments in the public service are vested in the Public Service Commission established under Section 84 of the Constitution. The PSC is therefore an important institution as it is responsible to observe the policy decisions regarding entry and promotion within the teaching service.



All government expenditure is centrally controlled by the Ministry of Finance. The Ministry therefore regulates the size and influences quality of the teaching service through the allocation of expenditure. In recent times, particularly under the World Bank Reform Project, the Ministry of Education has exhibited a preference for submitting its requests for additional resources directly to Cabinet, whose decisions supersede those of the Ministry of Finance.

Non-governmental organizations (NGOs) are also involved in education, though in a non-formal manner. The Christian Children's Fund works with disadvantaged children, and supports parents and children with materials, textbooks, and uniform and transportation allowances. The Fund also supports leadership training at the local level. The Social Centre and CALLS (the "Centre where Adolescents Learn to Love and Serve") provide skills training and life skills primarily for adolescents, young mothers and unemployed youth.

Several other NGOs and community-based organizations (CBOs) offer evening classes for external examinations such as CXC and GCE Ordinary- and Advanced-level subjects. These programmes are all aimed at enhancing youth skills and increase their chances of obtaining jobs. Significant contributions are also made by private companies through sponsorship of sports.

Structure and organization of the education system

Dominica: structure of the education system

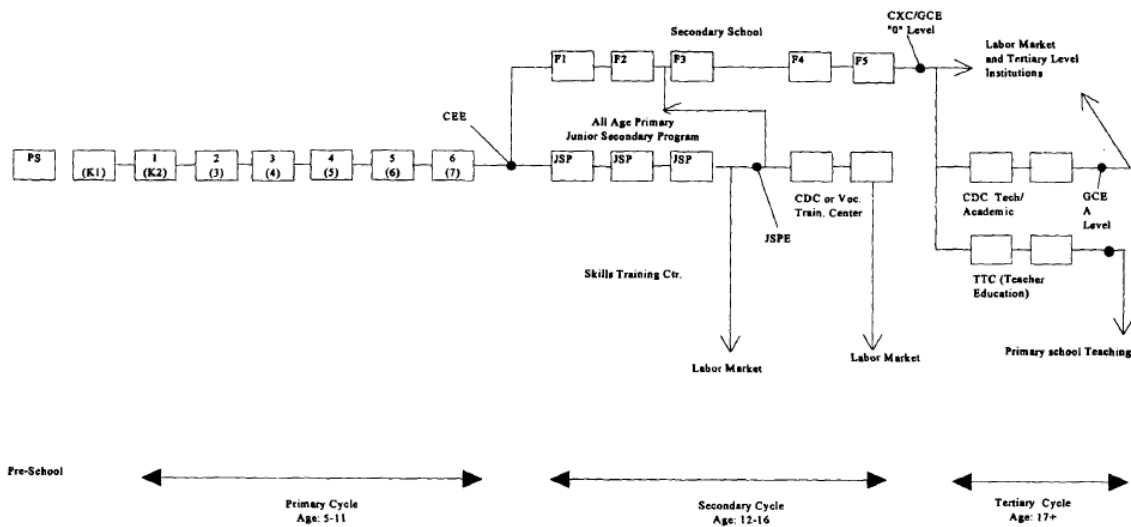

Source: World Bank 1995.

Pre-school education

Early childhood education (ECE) is optional and is offered through a variety of facilities (schools, day-care centres, crèches), largely by non-governmental organizations. A few nurseries exist and cater to the youngest children. ECE caters to children between the ages of 2½ and 5 years.

Primary education

Primary education is compulsory and usually begins at age 5, although some infants enter at age 4½. Primary education encompasses key stage 1 (covering kindergarten to grade 2) and key stage 2 (covering grades 3–6). At the end of grade 6, normally at age 10/11, pupils sit the Common Entrance Examination (CEE) for gaining access to secondary schools. Those students who are unsuccessful have another opportunity to obtain places through the Junior Secondary Programme Examination.

Secondary education

Secondary education is free at public schools and government-assisted schools (although some levies may apply at the latter) for all who pass the CEE. As a general rule, secondary education lasts five years, divided into two key stages: key stage 3, covering Forms 1-3; and key stage 4, covering Forms 4 and 5. In Form 5, students sit the General Certificate of Education (CXC/GCE) Ordinary-level examinations or the Caribbean Secondary Education Certificate (CSEC) examination administered by the Caribbean Examinations Council.



Higher education

Post-secondary and tertiary-level education is offered in a variety of institutions, both public and private. The main centre is the Dominica State College, a national publicly funded institution established in 2002 by merging the four publicly-owned tertiary education facilities existing at that time. This non-university institution offers programmes leading to the award of associate degrees (normally requiring four semesters of study), certificates (programmes lasting two semesters), or GCE Advanced-levels (two-year programmes). CSEC and GCE Ordinary-level holders can enrol in programmes leading to the CXC/Caribbean Advanced Proficiency Examinations (CAPE); programmes leading to the award of a certificate take one year to complete, while diplomas are awarded after successful completion of a two-year programme.

The University of the West Indies (UWI) provides opportunities through its School of Continuing Studies. These include first-year programmes of the Faculties of Arts and General Studies, Law and Social Sciences. Programmes leading to a bachelor's degree in education normally take four years to complete on a part-time basis. Certificate programmes are also offered.

Primary as well as secondary schools follow the same school year, which, on average, comprises 38 to 40 weeks of classes. However, in Form 5 of secondary education, classes usually end by mid-May to facilitate the final preparation and taking of external examinations. Generally, classes begin on the first Monday in September and end on 30 June, with breaks at Christmas and Easter.

The educational process

Prior to 1980, traditionally the curricula of both primary and secondary had been school based. Indeed, until the Curriculum Unit was established within the Ministry of Education in 1998, there were few curriculum guides in the key subject areas at the primary level and none at the secondary level. The primary school curriculum has mainly been driven by the high stakes Common Entrance Examination (CEE), while the secondary curriculum is largely determined by the Caribbean Examination Council (CXC) syllabi, textbooks and examinations. Two initiatives, however, commenced in 1995, and led to a review of the curriculum.

The first one was the Ministry of Education's policy of universal secondary education. The second initiative was the implementation of the Basic Education Reform and the Secondary Education Support projects. The former project led to, among other things, the establishment of a fully trained Curriculum Unit within the Ministry of Education, while under the latter project secondary curricula were developed in language arts, mathematics, science and social studies. Both projects enabled the expansion of the secondary system and the training of staff.

The Education Act of 1997 contains the statutory requirement to establish a national curriculum for public schools and assisted schools; it shall consist of core and foundation subjects. This curriculum must be balanced and broadly based, and must:

- a) promote the spiritual, moral, cultural, intellectual and physical development of

students and of society; and b) prepare students for the opportunities, responsibilities and experiences of adult life.

The goals and objectives of such a curriculum are articulated in Section 4(2) of the Education Act, which stipulates that the Minister is responsible to ensure the establishment and pursuit of goals and objectives that: a) encourage the development of basic knowledge and skills in all persons (including the skills of: literacy, listening, speaking, reading, writing; numeracy, mathematics, problem solving; information processing, computing; critical and creative thinking skills for today's world; an understanding of the role of science and technology together with scientific and technological skills; appreciation and understanding of creative arts; physical development and personal health and fitness; the creative use of leisure time); b) develop self-worth through a positive educational environment; c) promote the importance of the family and the community; d) provide opportunities to reach maximum potential; e) promote the recognition, understanding and respect for the Constitution, laws and national symbols of the state; f) develop further understanding of the principle of equality between the sexes; g) promote understanding of the indigenous people, history, language, culture, rights and values of Dominica and their changing role in contemporary society; h) increase awareness and appreciation of the natural environment of the state; i) promote a Caribbean identity through regional cooperation and integration; j) develop an understanding of the historical and contemporary role of labour and business in society; and k) prepare the people of Dominica for participation in the Dominican and global society.

In June 2001 a three-day consultation was held in Eggleston with some 40 stakeholders. The consultation drew up a framework for the purpose of establishing a National Curriculum. The framework called for the creation of a National Curriculum Steering Committee (NCSC) and National Curriculum Technical Committee (NCTC) to oversee the process. The NCTC had the responsibility of preparing the National Curriculum documentation while the NCSC, to whom the NCTC reported, was responsible for steering the process by ratifying or proposing amendments as necessary. The NCSC would then, through its Chairperson, make recommendations for approval to the Minister of Education.

Following approval of the initial proposals and, in keeping with standard policy development procedures, it was decided to elicit feedback from a wide cross-section of citizens. Three feedback mechanisms were approved: questionnaires, 'town hall' meetings and letters to special interest groups. Questionnaires asking respondents to identify aims and subjects that should be taught were administered to some 500 persons, stratified by age, gender and location. A further 200 letters with the initial proposals were sent to village councils, large employers, unions, church and other groups. Eleven 'town hall' meetings were conducted at key locations throughout the island. Parents, guardians, teachers, community leaders and officials of the Ministry of Education attended all sessions. The feedback from these meetings, the letters and the questionnaires were recorded, summarised and submitted to the NCTC for analysis.

The National Curriculum seeks to enable all learners to acquire the attitudes, knowledge and skills required to function productively in the modern world. In terms of the latter, cognisance is paid to Dominica's current and future economic



development, as well as the impact social challenges may, and currently do, pose. The National Curriculum is organized around principles and values such as: learning outcomes for achievement; learner-centred; shared values; quality learning experiences; high expectations; equity; harmonization; integration; progression; relevance; cooperation; and flexibility.

Every subject provides learning opportunities to promote the individual's spiritual, moral, cognitive, physical, social and cultural development; schools should be learning communities where students learn how to learn. Learning outcomes are the desired knowledge, skills, attitudes and values that all students have to demonstrate that they have achieved, in every subject, throughout the process. All students should learn and demonstrate, through the explicit and implicit aspects of the national curriculum, such values as compassion, generosity, honesty, patience, discipline, respect, caring for self and others, appreciation of learning, sense of belonging, self esteem and social responsibility. The National Curriculum Framework must provide a range and variety of quality learning experiences for all students in all subjects with particular emphasis on literacy and numeracy to sustain lifelong learning. Teachers and students are expected to perform at their highest levels so that all students, including those with special needs, realise their maximum potential.

The National Curriculum seeks to provide equality of access, participation in and benefit from quality learning opportunities and experiences for all in accordance with their individual needs and abilities. Measures to promote equity include affirmative allocation of resources and appropriate support at all levels of the education system.

The National Curriculum integrates the subject content, teaching, learning and assessment both within and across subject areas, where educationally appropriate. It progressively sets out increasingly complex, deeper and broader expectations of achievement in each subject through the key stages. The vertical and horizontal integration is to ensure a sound relationship with the conceptual progression from grade to grade and form to form. The National Curriculum aims to enable students to apply school learning to their daily lives as well as use their knowledge and skills acquired from out of school experiences as building blocks to enhance their learning in school. It seeks to promote cooperation and collaboration at all levels of the education system, from the classroom to headquarters, through dialogue, participation in decision making, responsibility for the process and the outcomes and, in so doing, ensure transparency for all stakeholders.

Finally, the National Curriculum Framework is designed to afford considerable flexibility for schools and students to customise the curriculum, subject to minimum policy requirements, to best meet the needs of the students. Schools are afforded 15% of curriculum time for their own choices that can include work experience, field trips, competitive clubs, performances etc. Flexibility in the organization of the school day to maximise learning opportunities relates to the organization of the timetable, the classroom, the methods of subject delivery, the use of limited resources and facilities and the choice of subjects offered at key stage 4.

The Education Act of 1997 prescribes the division of the years of compulsory education into four Key Stages and that learning outcomes will be specified for each



core and foundation subject through attainment targets, and laid out in the programmes of study for each subject. A learning outcomes curriculum is a structured hierarchy of inter-related outcomes that promotes a learner-centred and activity-based approach for all learners to achieve their maximum potential. It means that learners have to make sense of new knowledge in the context of their existing knowledge and so develop new understandings as learning takes place. The process of learning is as important as the final product. The final product includes the learning outcomes that all learners are expected to achieve in terms of knowledge, skills, values and attitudes by the end of the compulsory education cycle. The expected learning outcomes are made transparent to all stakeholders, including the students, before teaching and learning begins.

A learning outcomes curriculum recognises that learning at school is only truly beneficial when the learners can transfer or apply the learning to their daily lives beyond the school and can understand that learning is a life-long process. The learning outcomes in the National Curriculum, therefore, encourage students to engage in learning as a life-long activity, an essential pre-requisite to keeping pace with the ever-changing world of home and work. The developmental outcomes are the broad outcomes that all the learners are expected to achieve by the end of the National Curriculum cycle (key stage 4) both in and outside the school. They are derived from the national goals and they apply to both core and foundation subjects. They provide the base for the development of the attainment targets and learning outcomes which all students are expected to achieve as they progress from key stage to key stage. The attainment targets are what the learners should know, should be able to do and the desirable attitudes and values that they should display in each subject by the end of schooling; they remain the same throughout the key stages. Attainment targets do not stand alone and they are not on a one to one match with the subject strands; rather they collectively form a package to manage the curriculum. The attainment targets ensure integration and progression in the development of concepts, skills, attitudes and values through the learning outcomes. Attainment targets do not prescribe content or method.

A learner's achievement of the attainment targets is measured against the learning outcomes at the end of each year and key stage. They indicate for each subject strand the agreed basic depth and breadth of what learners should know, be able to do and the desirable attitudes and values they should demonstrate or display during, and at the end of, each key stage. While the number of learning outcomes to be outlined for each attainment target is not fixed, they should not exceed a pragmatic understanding of what knowledge, skills, values and attitudes the students can feasibly achieve within the specified curriculum time frame. A learner's progress toward each attainment target is seen in his/her ability to perform against learning outcomes at increasingly higher levels as he/she moves from grade to grade and from key stage to key stage. The learning outcomes, together with the attainment targets are laid out in the programmes of study for each subject.

Success criteria are derived directly from the individual learning outcomes. They describe what the learner must know, be able to do or attitudes they must display to indicate or demonstrate that they have attained the learning outcome. The success criteria therefore act as stepping-stones to achieve the learning outcome. The success criteria are laid out in the non-statutory subject curriculum guides.



Each subject has a programme of study that defines the subject, its scope and unique features and its contribution to the curriculum. The programme of study sets out the attainment targets for the subject strands and the expected learning outcomes of knowledge, skills, desirable attitudes and values that learners of different abilities and maturities are expected to achieve during and/or at the end of each key stage. Thus, the programme of study forms the scope and sequence chart for the subject areas of the National Curriculum.

Core subjects run throughout the four key stages. They are compulsory for all students through key stages 1–3. Foundation subjects are optional subjects that students can select for study in key stages 3 and 4. At key stage 4 each student shall be required to study subjects selected from the aggregate of core and foundation subjects. Each core subject is defined through the National Curriculum Framework as an organized body of knowledge, skills, values and desirable attitudes that shall serve as a cornerstone for further learning. Each core subject has a definition from which its essential strands are derived for learning purposes. Each core subject has no more than five strands where the strands represent the learning intentions.

The compulsory curriculum should not take up more than 85% of the instructional time available so that schools can use the 15% curriculum time for other subjects (e.g. religious education, indigenous knowledge) or to increase instructional time for timetabled subjects where deemed necessary. It is recommended that schools increase the minimum instructional time to provide sufficient opportunities for all students to achieve the outcomes especially at secondary level.

The framework document outlines the core and foundation subjects that are to be taught in all public and assisted private schools. The actual subject content for these subjects will be defined by the programmes of study and attainment targets to be articulated for each of the four key stages. The framework also gives guidance to schools on the minimum time they should allot to each of these subject areas during any key stage. Within this framework schools have considerable flexibility to customise the curriculum to best suit the needs of their students. Schools are to determine their own goals, objectives and how they will be achieved. The school's mission statement and school development plan (SDP) should clearly articulate these. To achieve some of their targets, some degree of curriculum differentiation may be necessary. Schools may also decide to teach subjects thematically or combine certain subject areas. For example, a school may wish to use a thematic approach in K to grade 2. No specific subject areas are specifically identified on the timetable. Rather work revolves around themes. Alternately, a school may wish to split certain aspects of a subject area and teach them separately. It should be noted that the curriculum is not determined by the subject name or what elements of the curriculum that are grouped together but rather by the attainment targets.

In order to achieve their mission, schools may wish to add additional subject areas to the curriculum. Some percentage of the curriculum time is given to school choice. To this end, schools can add additional subjects or learning experiences. In some cases schools may wish to extend the school day to provide students opportunities to engage in work attachments, field trips, competitive sports, clubs and the like. (Ministry of Education, 2006).



Pre-primary education

The main objectives of early childhood education (ECE) are to: equip young children aged 3-5 with the necessary skills to adjust successfully to the primary school; provide an environment that stimulates the development of these children socially, intellectually, spiritually and creatively; create a partnership between teachers, parents and the community, and to reinforce the critical role played by the community, parents and caregivers in the lives of these young children.

Early childhood education (ECE) is not compulsory in Dominica. Traditionally, this role has been played by NGOs and private individuals. The Social Centre—a Catholic-sponsored NGO—has been the leader in providing pre-primary education. For several years, the Centre obtained generous funding from the Bernard Van Leer Foundation, a European NGO that supported administrative staff costs and teacher training. All the major population centres offer early childhood care and education.

On average, children spend between 24 to 26 hours per week at ECE facilities. There are no formal evaluation methods and most programmes are designed to prepare children for entry into primary school. However, it is generally agreed by parents, community and education officials that these early interventions impact positively on the children.

The average time spent in activities is as follows: pre-academic (language arts, mathematics, science, social studies): eight hours per week; personal care/social activities: seven hours per week; singing, story telling, physical education: five hours per week; play time, creative acts: three to five hours per week.

It is estimated that 70% of children in the age group 3-5 years attend pre-schools. Under the new ECE regulations, the Ministry of Education will, through the ECE Council, work to ensure that schools are registered and their facilities are in compliance with the regulations. The Ministry of Education will also work closely with the Council to assist them in the development of curriculum whose content is, generally, in line with the national curriculum and is age appropriate. The Ministry of Education, through the ECE Council, will work to promote ECE with the goal of ensuring universal pre-school attendance. Both Education and Curriculum Officers from the Ministry of Education will work to establish linkages with the ECE Council to seek their advice in matters relating to ECE and to foster better communication between feeder pre-schools and primary schools.

In accordance with the ECE Regulations of 2003, ECE institutions must implement a programme which must be based on sound theory and practice and reflect an integrated and holistic approach to early childhood education, must be appropriate to the ages and circumstances of the children attending the facility, and must be geared to stimulate the physical, social, cultural, emotional, cognitive and spiritual development of the child. The programme must include a relevant environmental education component in order to give the children an appreciation of the need to preserve the natural environment of the Commonwealth of Dominica.

The daily programme shall be well balanced and designed to meet the developmental needs of the children; it shall: a) be formulated to reflect objectives



that are contextual, sequential and show the interconnection between the short-term and long-term goals; b) be flexible and varied in order to provide the opportunity for language development and stimulate creativity; c) provide the children with opportunities to work out social relationships through play and experience; provide the children with opportunities for indoor and outdoor play activities; e) provide for regular rest periods on a daily basis appropriate to the age of the children; and f) in the case of children with disability, appropriate services for their convenience. The programme shall also provide for scheduled parent or parent organization involvement and education.

Every principal of an ECE facility shall complete a course of study in management and supervision of schools or some equivalent qualification from an institution recognised by the Ministry. Teachers working with children under the age of 3 shall have completed a course of study in ECE or received some equivalent qualification from an institution recognised by the Ministry. Teachers working with children aged 3-5 years shall have completed five years of secondary education, and completed a course of study in ECE or received some equivalent qualification from an institution recognised by the Ministry. Every aide or volunteer shall have completed at least two years of secondary education, unless the Minister, on the advice of the Council, exempts the aide or volunteer from such qualification requirement.

In 2002, there were 85 preschools, including 19 publicly assisted and 66 private institutions (of which 26 were owned and administrated by religiously affiliated organizations) (World Bank, 2005). According to national sources, in 2003/04 the total enrolment in government, private and government assisted facilities was 1,812 children. According to the UNESCO Institute for Statistics, in 2007 the total enrolment was some 1,900 children.

Primary education

Primary education is compulsory and free; normally it begins at age 5 although children are accepted at age 4½ especially in denominational government-assisted schools. Primary education covers key stage 1 (kindergarten to grade 2) and key stage 2 (grades 3 to 6). It is during these key stages that a child's character and attitude towards learning life are developed and shaped. Schools should therefore create a safe, engaging learning environment that will motivate the child to learn and achieve.

According to the National Curriculum Framework, the core subjects are: languages; mathematics; science and technology; agriculture; social sciences; health and family life education (HFLE); visual and performing arts; and physical education and sports. Languages include oral French and Spanish from key stage (KS) 2 onwards. Where children come to school without English as a home language then extra-time is allocated to support their acquisition of English and learning is through the mother language or vernacular. Agriculture is incorporated, as a subject strand, in 'science, technology' for KS1 and 2; in KS3 it taught as a separate subject and in KS4 becomes a foundation (optional) subject. The focus of HFLE in all four KS is the holistic development of the individual student so that each can acquire the knowledge and skills required to play an effective role as healthy, responsible citizens in society; it incorporates health, social skills including parenting, domestic finances, career guidance and counselling in KS3 and KS4.



During KS1 (kindergarten to grade 2), the emphasis is on the development of languages especially basic literacy and numeracy skills. Thus, a minimum of 13 hours per week will be devoted to the acquisition of those skills. Science has been allocated 2.5 hours per week as it incorporates technology and agriculture. During KS2 (grades 3-6), the time allocated to the social sciences has been increased so that elements of history, civics and social justice can be included. Information and Communication Technology (ICT) may be timetabled for specific instruction or integrated into the other subjects to promote learning about, and through, information technology. The requirement for community service is in line with the cultural heritage of self-help and the principle of valuing one's community by giving back as well as receiving. Community work will be organized so that records of projects and undertakings and the pupils' participation and achievements are systematically planned and reported to the community organisations, schools and parents. Pupils in KS1 and 2 will be guided in the choice of community work by the school, especially by the HFLE and social science teachers. It could range from talking and reading, and writing for citizens both young and old who are identified as in need, to cleaning the home, school and local environment and visiting the sick in hospital etc.

Subject areas are divided into subject strands that are the key elements of a subject and are derived from the developmental outcomes. They comprise the content which the learner has to demonstrate mastery to achieve the learning outcomes and attainment targets. The strands for the seven core subject are the following:

- Language arts: Listening & speaking; reading; writing.
- Mathematics: Number; geometry; measurement; statistics & data handling; patterns, functions & algebra.
- Science: Life science; earth & space science; physical science; agriculture.
- Social science: Civic ideals & practices; location, people & places; resources; social issues & change.
- HFLE: Social, emotional & spiritual well being; eating & fitness; sexuality & sexual health; managing the environment;
- Visual and performing arts: art & craft; music; drama & dance;
- Physical education and sports: physical education & sports.

The table below outlines the hours allocated to each subject for each KS in compliance with the five and a half hour instructional period per day excluding the 15% school choice curriculum time as well as 20 hours minimum community service per key stage:

Dominica. Hours per week allocated to subjects for each key stage

Subject	Average number of weekly hours per key stage			
	KS1	KS2	KS3	KS4
Languages	8	8	6	3
Mathematics	5.5	5	3.5	3
Science & technology including agriculture	2.5	2.5	–	3
Science & technology excluding agriculture	–	–	2.5	–
Agriculture	–	–	1.5	–
Social sciences	2	2.5	2	3
HFLE	2	2	2	3
ICT integrated	1	1	1	2
Physical education	1.5	1.5	1.5	1.5
Visual and performing arts	2	2	2	3
Vocational 1	–	–	2.5	3
Vocational 2	–	–	–	3
Vocational 3	–	–	–	3
Total weekly hours	24.5	24.5	24.5	24.5

In addition: 15% of curriculum time for school choice;
20 hours of community service each year for all KS

Source: Ministry of Education, 2006.

Assessment is normally seen to have two main purposes. One is formative where the aim is to gather information that will enable the next steps in learning to be planned. Formative assessment identifies what a pupil has learned through a particular programme or task and in what areas he or she needs to do more work. Formative assessment is sometimes called assessment for learning and is an essential part of the process by which a teacher monitors the progress of an individual pupil and develops the process of learning. Since the learning programme is conducted within the curriculum, formative assessment takes account of the expected learning outcomes but is primarily concerned with supporting the learning steps by which a pupil reaches the expected outcomes than simply measuring whether the outcomes have been met. The second purpose is summative. Here the concern is to determine whether expected learning outcomes have been met as a result of a learning programme. Summative assessment may have a range of purposes including determining the effectiveness of a learning or teaching programme, certificating the attainment of individual pupils, enabling selection or monitoring whether a school or education system is meeting expected targets.

Formative assessment may involve marking class work or homework, observing the pupil undertaking an activity, listening to reading or speaking or asking



questions in class. Pupils then need to know, through effective and constructive feedback, how they have performed and then be involved in the process of agreeing to new activities. These activities are likely to be many and varied to provide for the pupils' different learning styles and different levels of mastery of concepts and skills. Some of the evidence collected in this process can be selected and compiled by the learner, supported by the teacher, to be put into a container called the Learner's Portfolio together with the Learner's Achievement Record.

At the end of grade 6, normally at age 10/11, pupils sit the Common Entrance Examination (CEE) for gaining access to secondary schools. Those students who are unsuccessful have another opportunity to obtain places through the Junior Secondary Programme Examination.

According to the provisions of the National Curriculum Framework, national assessments will be undertaken around the end of each of the four key stages. The overall purpose of the national assessments for the first two key stages shall be to improve teaching and learning in the school system. The focus of the assessment at KS1 and KS2 is therefore diagnostic. The information is to be used to identify and provide support through remediation programmes to those students who experience barriers to learning as well as to design appropriate programmes for children with different special needs. A structured monitoring system with systematic information flow will be introduced alongside the national assessments to ensure that students with difficulties are identified and the necessary support programmes provided. This will be essential in KS1 so an Early Identification Checklist (EIC) shall be used to monitor the performance of students from pre-school to the end of grade 1. The EIC will enable teachers to identify students who may benefit from early intervention. In principle, the national assessment at KS2 shall replace the CEE, which, with the introduction of universal secondary education policy, shall no longer be relevant. The national assessment results at the end of KS2 will be shared with the primary and secondary schools to assist them in planning a continuum of quality programmes aimed at assisting students to achieve the learning outcomes across the subjects. National assessment at Key Stages 1-3 shall be nationally designed and distributed but administered and marked by the schools. All schools will do national assessments according to the same timetable across the state. Student results shall be recorded on a national report and submitted to the Curriculum and Evaluation Unit, through a national data collection system, by a pre-determined date. (Ministry of Education, 2006).

Students with special needs fall within a continuum ranging from those with severe mental, physical, sensory, communication and behavioural deficiencies to those who are exceptionally gifted and talented. The Ministry of Education's long-term goal is to ensure that as many students with special needs as possible benefit from the goals and objectives of the established national curriculum within the most enabling environment that resources permit. The Ministry will, as far as possible and subject to availability of resources, seek to meet the needs of all students within the regular school environment. The Ministry believes that the outcomes in early childhood, primary and secondary education, are germane to all learners, and therefore where applicable, the curriculum will be adapted or modified through the development and implementation of Individual Education Plans (IEP). An IEP is an instructional programme tailored to the needs of an individual learner focusing on



his/her strengths and weaknesses. For students with moderate to severe challenges, the Ministry will seek to include functional academic, daily living, self-help and communication skills. At all levels within the education system, alternative instructional and assessment models will be explored and may be adopted. The Ministry will also seek to provide appropriate and affordable technology to aid communication, mobility and the total development of the child thereby enhancing the child's success in the school curriculum.

In 2003/04, the total enrolment in primary education was 9,872 pupils, representing a net enrolment rate of 87%. The pupil/teacher ratio was 19:1. The total number of new entrants to primary schools was 1,098, and the transition rate from primary to secondary was 94%. The total number of repeaters in 2004 was 429, representing 4% of the primary school population, and the survival rate to the last grade of primary was 84%. According to the UNESCO Institute for Statistics, in 2007 the total enrolment was about 8,600 pupils. Access to primary education is almost universal.

Secondary education

Secondary education is free at public schools and government-assisted schools (although some levies may apply at the latter) for all who pass the CEE. As a general rule, secondary education last five years, divided into two key stages (KS): key stage 3, covering Forms 1-3; and key stage 4, covering Forms 4 and 5. In Form 5, students sit the General Certificate of Education (CXC/GCE) Ordinary-level examinations or the Caribbean Secondary Education Certificate (CSEC) examination administered by the Caribbean Examinations Council. CSEC and GCE Ordinary-level holders can enrol in post-secondary programmes leading to the CXC/Caribbean Advanced Proficiency Examinations (CAPE); programmes leading to the award of a certificate take one year to complete, while diplomas are awarded after successful completion of a two-year programme.

During KS3 (Forms 1 to 3) the time allocation reflects the need for a balanced and broadly based curriculum to both challenge and meet the needs of the students with varying dispositions and attitudes on entering secondary schools under the universal secondary education and in preparation for awarding the National Certificate of Basic Education. In KS4, a student shall be required to study a minimum of 5 subjects but usually no more than 7 subjects. Each of the subjects, therefore, has an equitable 3 hours time allocation for the normal maximum number of subjects (seven) that the curriculum allows. Students who select the minimum requirement of 5 subjects shall have time for further study in those 5 subjects according to needs as identified through the assessment arrangements. Schools who wish that students take additional subjects may need to arrange extra lessons for them. All KS4 students shall be required to undertake a minimum of 1.5 hours of physical education and sports per week. This would be extra-time for those students who elect physical education and sports as a foundation subject in KS4. The allocated subject times may not be sufficient for all students in all subject areas. Schools will be encouraged to be flexible in timetabling to meet the different needs of all their students. An increase in the length of the school day or a different time management of the school day may be needed to address these issues. As regards the community service, students in KS3 and 4 could choose their areas of work, in collaboration with



school and community, and could range from work experience, to mentoring activities, to supporting drug awareness campaigns, youth literacy programmes and community cleaning campaigns etc. The 20 hours' community work could be completed in monthly /termly or holiday time blocks.

The national assessment at KS3 shall have a dual purpose. It shall, with the continuous assessment records for KS3, form the basis for awarding the National Junior Secondary Certificate. Secondly, the students may use their own results against the Ministry of Education's list of selection criteria to decide their subjects for the CXC. The results shall also provide diagnostic information in terms of a student's needs within the subject choices for focused attention during KS4. There will be no distinct national assessment at KS4. Schools will set their own pre-CXC and other internal examinations and KS4 will end with the CXC and other external examinations. Each student shall receive a National Record of Achievement issued by the school at the end of KS4. The record of achievement shall include the accomplishments of the student in their years of schooling.

According to the National Curriculum Framework, at the end of KS4, students should be able to:

- communicate competently and effectively in standard English orally and in writing, demonstrating the use of advanced literacy skills with a range of different people and purposes;
- read and listen to a variety of texts (print, visual and media) with understanding for the purposes of learning, social interaction and pleasure;
- calculate and estimate with speed and accuracy;
- apply knowledge, skills and reasoning to their daily lives;
- demonstrate the use of different methods, including scientific methods, to solve problems;
- use information technology skills competently and effectively for a variety of purposes;
- have a working knowledge of a modern language other than English;
- exhibit positive work attitudes;
- understand and demonstrate respect for the law, the family, society, the rights and responsibilities of others;
- understand and demonstrate a commitment to physical fitness, good healthcare and a productive life style;
- demonstrate a high level of self-worth;
- make sound moral and ethical judgments;
- show a capacity to live and work harmoniously with others;
- appreciate and conserve the national environment and cultural heritage;
- demonstrate a commitment to the community and national development;
- demonstrate an understanding of their roles and responsibilities as citizens;
- demonstrate different ways to continue learning throughout their lives.

In 2003/04, the total enrolment in secondary programmes (high schools) was 7,206 students with 50% being female. The student/teacher ratio was 17:1. The overall repetition rate was 10.8% (12.5% in Form 1, and 17.6% in Form 2).



Assessing learning achievement nationwide

As mentioned, the National Curriculum Framework stipulates that national assessments will be undertaken around the end of each of the four key stages. The overall purpose of the national assessments for the first two key stages shall be to improve teaching and learning in the school system. The focus of the assessment at KS1 and KS2 is therefore diagnostic. The information is to be used to identify and provide support through remediation programmes to those students who experience barriers to learning as well as to design appropriate programmes for children with different special needs.

A structured monitoring system with systematic information flow will be introduced alongside the national assessments to ensure that students with difficulties are identified and the necessary support programmes provided. This will be essential in KS1 so an Early Identification Checklist (EIC) shall be used to monitor the performance of students from pre-school to the end of grade 1. The EIC will enable teachers to identify students who may benefit from early intervention. In principle, the national assessment at KS2 shall replace the CEE, which, with the introduction of universal secondary education policy, shall no longer be relevant. The national assessment results at the end of KS2 will be shared with the primary and secondary schools to assist them in planning a continuum of quality programmes aimed at assisting students to achieve the learning outcomes across the subjects. National assessment at Key Stages 1-3 shall be nationally designed and distributed but administered and marked by the schools. All schools will do national assessments according to the same timetable across the state. Student results shall be recorded on a national report and submitted to the Curriculum and Evaluation Unit, through a national data collection system, by a pre-determined date. (Ministry of Education, 2006).

Teaching staff

Four CXC/GCE O-level subjects are required to teach at the primary level. Until recently, any four subjects with English language would satisfy education officials. This minimum was consistent with requirements for entry into the public service.

As of 1997, the Ministry requires four subjects, which includes English language, mathematics, science, and social studies at stipulated grades. These subjects reflect the streams taught. All teachers are appointed by an Independent Public Service Commission. According to the early childhood education (ECE) Regulations of 2003, every principal of an ECE facility shall complete a course of study in management and supervision of schools or some equivalent qualification from an institution recognised by the Ministry. Teachers working with children under the age of 3 shall have completed a course of study in ECE or received some equivalent qualification from an institution recognised by the Ministry. Teachers working with children aged 3-5 years shall have completed five years of secondary education, and completed a course of study in ECE or received some equivalent qualification from an institution recognised by the Ministry. Every aide or volunteer shall have completed at least two years of secondary education, unless the Minister, on the advice of the Council, exempts the aide or volunteer from such qualification requirement.



There are four categories among the teaching staff. These are: a) specialist teachers have received teacher training plus specialist training, e.g. woodwork, home economics/management or counselling; b) graduate teachers have obtained a university degree with or without specialized education training; c) qualified teachers have received teacher training with a certificate or diploma, usually after two years of study beyond GCE O-level; d) unqualified teachers have their O-level without formal teacher training.

Full-time courses at the Teacher Training College last two years (beyond secondary education) and include several weeks of practical teaching in the classroom. The content focuses on core subjects together with areas of psychology and other social sciences.

Secondary school teachers must have GCE A-level pass(es) in the subject(s) to be taught. University degrees are preferred. A university degree is a prerequisite for teaching at tertiary institutions. Teachers at technical and vocational institutions enter with a variety of qualifications.

Teachers' workloads vary considerably. Primary school teachers on average spend thirty hours per week in classroom preparation and teaching activities. Secondary school teachers spend approximately ten to fifteen hours per week in classroom teaching.

Salaries and conditions of work are based on relativities within the public service with reviews every three years. Promotion tends to be limited after one has reached the level of principal, although some may pursue further studies and move to administration, college teaching or more technical areas like curriculum development.

References

Henry, R. *Cost and financing of education in Dominica*. May 1995.

Bray, M. ed. *Ministry of Education in small states. Case studies of organisation and methods*. London, Commonwealth Secretariat, 1991.

Green, Hon. R. *Minister of Education strategy letter*. Ministry of Education, Sports and Youth Affairs. Basic Education Reform Project, Dominica, September, 1996.

Central Statistics Office. *Education statistics No. 2*. Ministry of Finance, Commonwealth of Dominica, 1997.

Ministry of Education. *Education For All 2000 Assessment: report of The Commonwealth of Dominica*. (Under the co-ordination of Max Andrew). Roseau, June 1999.

Ministry of Education. Education Planning Unit. *Planning parameters and projections to 2005, Document No. 8*. June 1998.



Ministry of Education, Human Resource Development, Sports and Youth Affairs.
National Curriculum Framework for Dominica. April 2006.

UNESCO Institute for Statistics. *Global Education Digest 2009: Comparing Education Statistics Across the World*. Montreal, UNESCO:UIS, 2009.

WHITCO Inc. *Education profile of the Commonwealth of Dominica*. Prepared for the International Bureau of Education, Roseau, Dominica, September 1998.

World Bank. *Commonwealth of Dominica. Basic education reform project*. Staff Appraisal Report, November 1995.

World Bank. *Dominica OECS Fiscal Issues. Policies to Achieve Fiscal Sustainability and Improve Efficiency and Equity of Public Expenditures*. Caribbean Country Management Unit, Poverty Reduction and Economic Management Unit, Latin America and the Caribbean Region. Washington DC, June 2005.

Web resources

Ministry of Education and Human Resource Development:
<http://www.education.gov.dm/> [In English. Last checked: June 2010.]

For updated links, consult the Web page of the International Bureau of Education of UNESCO: <http://www.ibe.unesco.org/links.htm>